

**DIY INSTRUCTIONS**  
FOR YOUR OWN GROWING SURFACES





# **NATURE IS SOMETHING BEAUTIFUL.**

This do it yourself guide is for those who love nature and want to make their furniture grow with small plant walls. With everyday materials, a practical garden can be planted directly on doors and beautify every home.

## WHAT DO YOU NEED:

First you need a grate to hang the flower boxes. This can be angular or round. Next, you need tapes (10m) in your favorite color, clip caps, needle and thread. For the flower boxes we recommend cans with a window, felt, glue, small hooks (must fit on the grill) and of course your favorite plants or herbs must not be missing. Especially good for the indoor air are Lilyturf, Englishivy, varigated snake plant and as herbs especially chives, cress, sage, oregano etc.

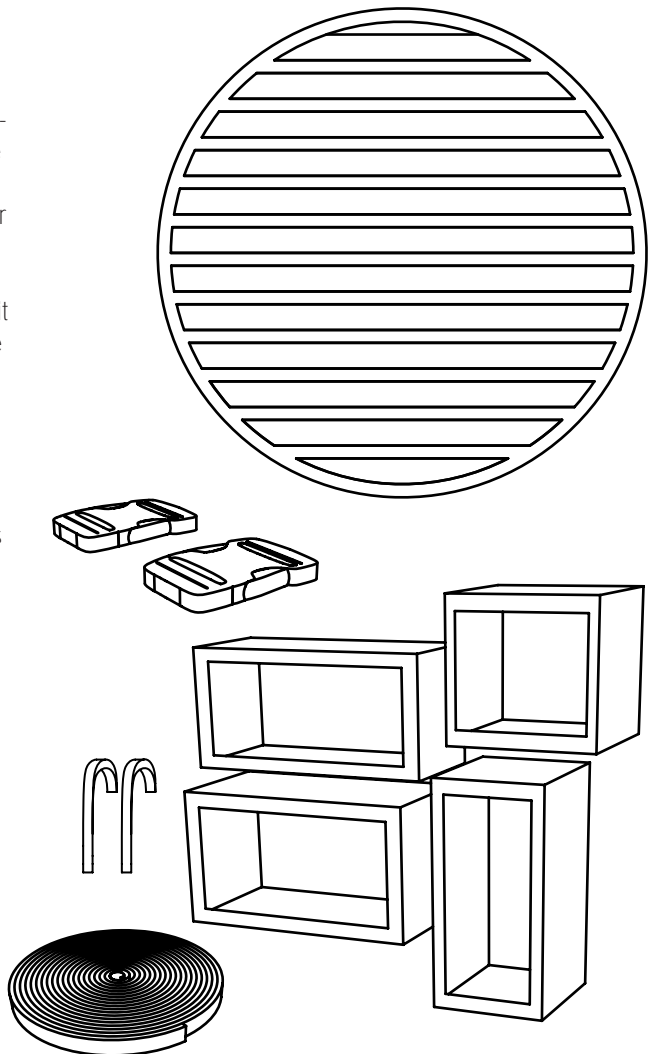

# OVERVIEW

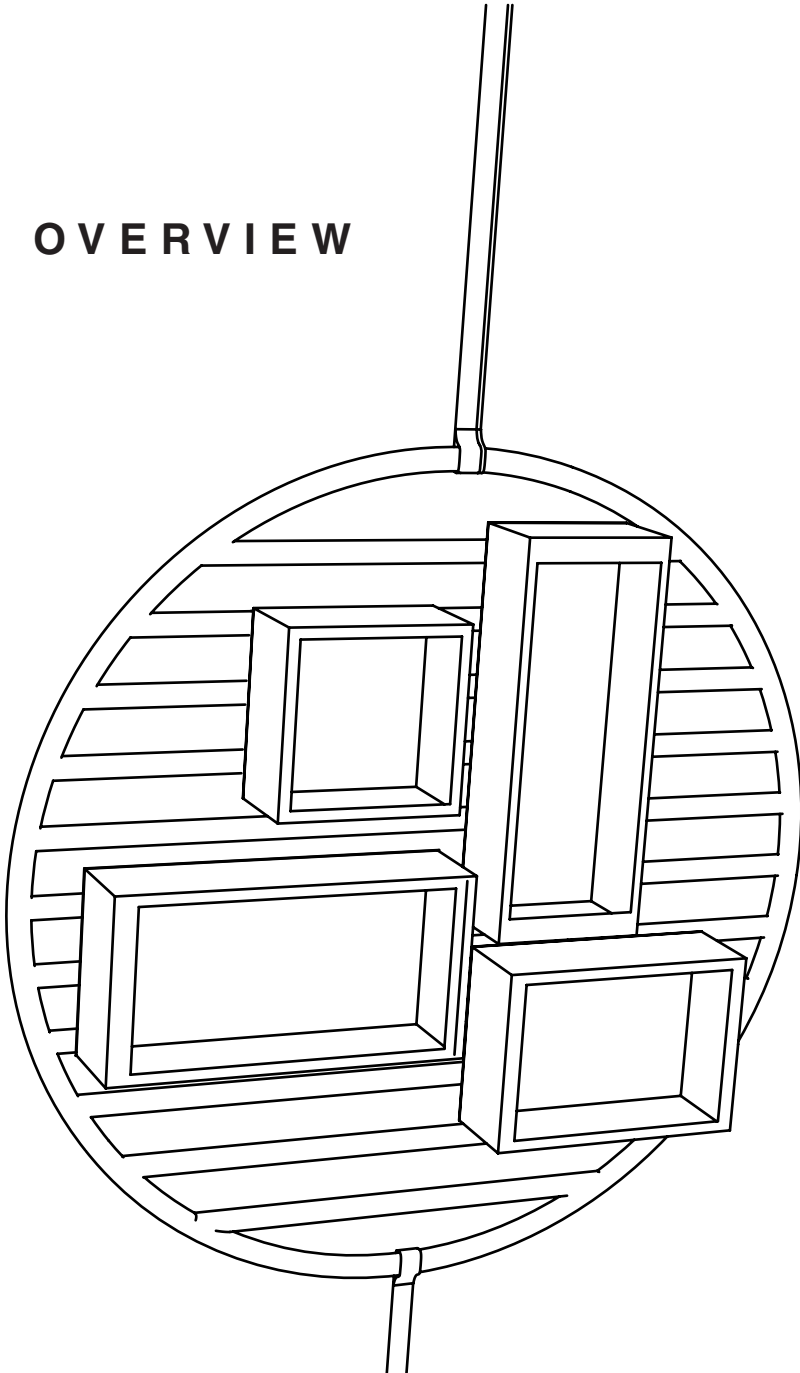

## FIRST STEP

First you have to cut the string into two pieces. It is advisable to adjust the length to the wall of the cabinet to which the grill will be attached.

The second is to wrap the string around the top two ends of the grill grate. Then needle and thread are used. With a few needle stitches, the cord is now attached to the grill.

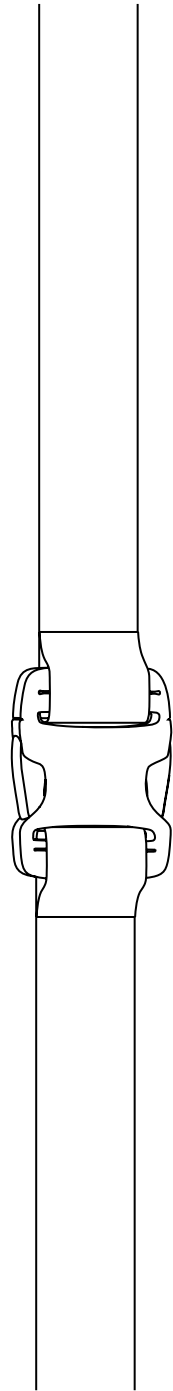
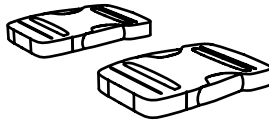
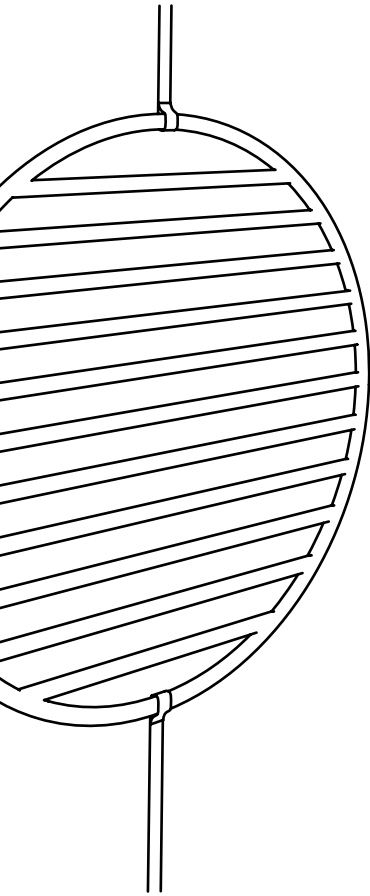

## SECOND STEP

Finally, the viewing windows are taken from the cans and the hooks are glued to the back. And now the plants can also be used. Instead of soil, substrate should be taken, thus the plant pots are lighter and you have to pour them less often. In addition, you can lay felt on the soil of the plant and clamp the felt and plant under the lid, so no soil can fall out when the flowerpots hang vertically on the wall.

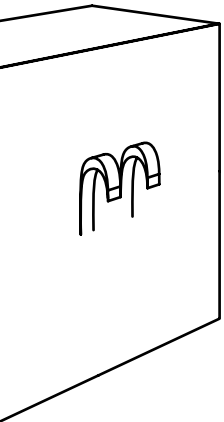
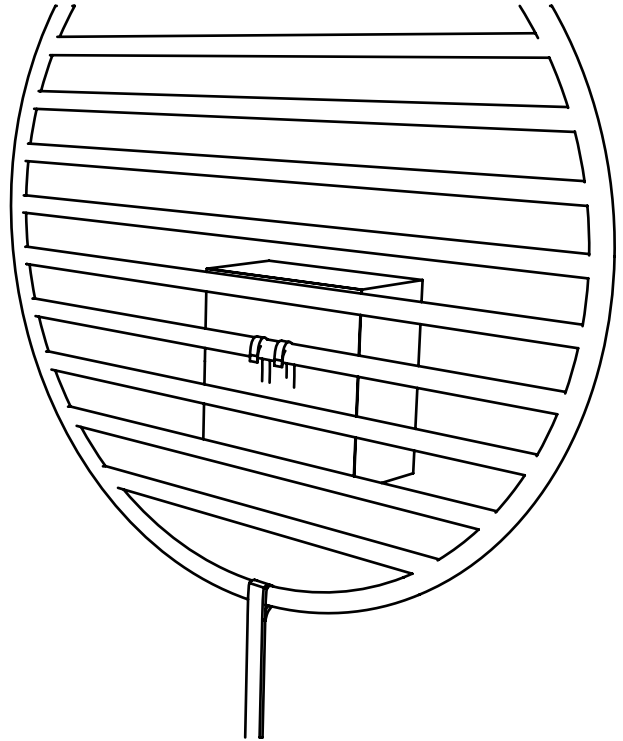

**AND NOW,  
ENJOY!**

C o n t a c t  
Sarah Stapelfeldt  
sarah.stapelfeldt@t-online.de  
Industriedesign  
Hochschule München  
Fakultät für Design